



Inis Stoves
Unit 8-9, West Link Business Park,
Oranmore, Co. Galway,
Ireland

LoCall 1890 911 411
Tel +353 91 399 800

www.inisstoves.ie



SUPERIOR QUALITY STOVES





Like our Ancestors, we are drawn to the light and heat of a real fire. Fire is part of our DNA, a real fire makes us feel instantly relaxed and secure. At Inis Stoves we produce high quality solid fuel stoves that allow you to safely and efficiently manage the heat and flames of a real fire in your own home.

Every stove that we produce will become an integral part of your home and daily life. We are aware of the time that will be spent by our customers looking into an Inis Stove, watching the flames dance. Each Inis Stove is destined to become a focal point of someone's home and all have been designed with this in mind. Our stoves have been crafted to enhance the aestheticism and convenience of a real fire whilst allowing you to maximise the efficacy and heat output through the use of discrete, technological innovation.

Inis Stoves offer you beauty and simplicity, combined with safety, ease of use and efficiency. These are our core principles and the flames that burn within every Inis Stove help our customers to appreciate this.





About Inis Stoves

At Inis Stoves great care and attention has been put into the development of each and every stove we produce, across all ranges and models. We believe in continuous improvement, which is why you will find that Inis Stoves offer a range of features that surpasses those of other manufacturers.

All Inis Stoves are designed, built and assembled in Ireland to the very highest quality standards. We are a wholly owned Irish company, creating domestic jobs that promote the local and national economy.

Boiler Stoves

The boiler stove products manufactured today boast little advance or improvement on those produced decades ago. There has been limited innovation in the areas of user comfort, stove efficiency or stove fundamentals. At Inis Stoves we have been focusing on the problems of boiler stove design and we are delighted to announce the launch of our Mark 2 range of ultra-efficient, ultra clean boiler stoves.

In designing our Mark 2 boiler range we have removed the heat exchanger from the firebox. When the heat exchanger is in the firebox, which is standard for almost every boiler stove on the market, sooty deposits build up on the boiler, the glass and the chimney ways, permeate a sooty odour and prove very difficult to clean.

To introduce this design augmentation is a simple yet technically challenging idea, it took us 3 years of development and testing to fine tune our new range for optimum performance. We are now delighted to launch the upgraded range of boiler stoves that are ultra-efficient, clean, easy to use and a joy to watch in the comfort of your home.

Our new design also incorporates increased air-wash capacity and thorough pre-heating for perfectly clean viewing glass. Lengthened combustion air pathways deliver excellent pre-heating and a riddling grate with separate positions for various fuels results in proper combustion of wood and solid fuels. The improved riddling grate design is easily operated even when heavy solid fuel ash is present.

Along with the re-arrangement of the heat exchanger/firebox assembly we have engineered the following improvements;

- Side split cast iron baffle plates for excellent heat reflection back into the firebox, this gives added combustion efficiency.
- A much greater range of outputs can be achieved as the fire doesn't have to be kept relatively high to maintain itself in a cold firebox.
- Large viewing glass for the largest view of the fire possible.
- All stoves are now external air ready.
- Easy access to the flueways for chimney cleaning.

To look at all the improvements in more detail please view our new range of boiler stoves on the following pages.





InisMor MK 2 BOILER

The InisMor Mark 2 is the largest boiler stove that Inis Stoves produce and it is designed to satisfy the most demanding of central heating applications.

As the price of home heating oil and gas continue to rise the InisMor MK 2 is an excellent cost effective method of delivering sustainable, dependable heat all year round and when fuelled with wood can deliver low carbon heating.

As with the InisOirr MK 2 and InisMeain MK 2, the InisMor MK 2 has a unique boiler and firebox arrangement that greatly improves both the stove efficiency and ease of use for the customer.

Fuel is burned in a very high temperature firebox that liberates a large percentage of the possible energy within the fuel before passing the gases from combustion through a highly efficient heat exchanger that quickly heats the water within the boiler. This system is much cleaner and more efficient than all other typical boiler designs that drastically reduce combustion efficiencies by depriving the fire of heat too early in the combustion process.

Like all Inis Stoves models, all the combustion air, primary, secondary, tertiary and air wash is guided through long passageways within the stove gaining heat along the way that greatly increases combustion efficiency and temperatures within the firebox.

It has a very large firebox capacity to facilitate longer burn times and can take wood logs of over 700mm in length. The multi-fuel grate is composed of individual riddler bars that can be used in two different positions to facilitate proper combustion of wood, peat and solid fuels.

The InisMor MK 2 has a nominal boiler output of over 18.5kw and if needed can easily deliver 21.5kw by increasing the burn rate. This stove will easily heat 18 standard radiators along with your domestic hot water and can also be used to heat under-floor heating.

The stove is external air ready with the use of a bolt on manifold and our cool touch handles, made of Walnut, allow for safe and easy use.



FEATURES

- Output: To water 18.5Kw nominal, 21.5Kw max
- Output: To Room 9.5 Kw nominal, 12.0Kw max
- Comfortably heats 18 standard radiators along with domestic hot water.
- Heavy duty cast iron baffle plates provides excellent elevated firebox temperatures.
- “Easy start” damper for quick lighting of the fire.
- Multi-fuel grate designed to burn wood, peat and smokeless coal as they should burn.
- Extra strong grate for long life under the harshest of operating conditions.
- Primary, secondary and tertiary air perfectly managed through one control.
- Exceptionally effective pre-heated air wash system provides crystal clear viewing glass.
- Unique convection air system within the stove to aid efficiency.
- Manufactured to stringent ISO 9001-2000 standards.
- 5 Year warranty.
- External air ready.
- Overnight burning capable.
- Choice of 6 colours.

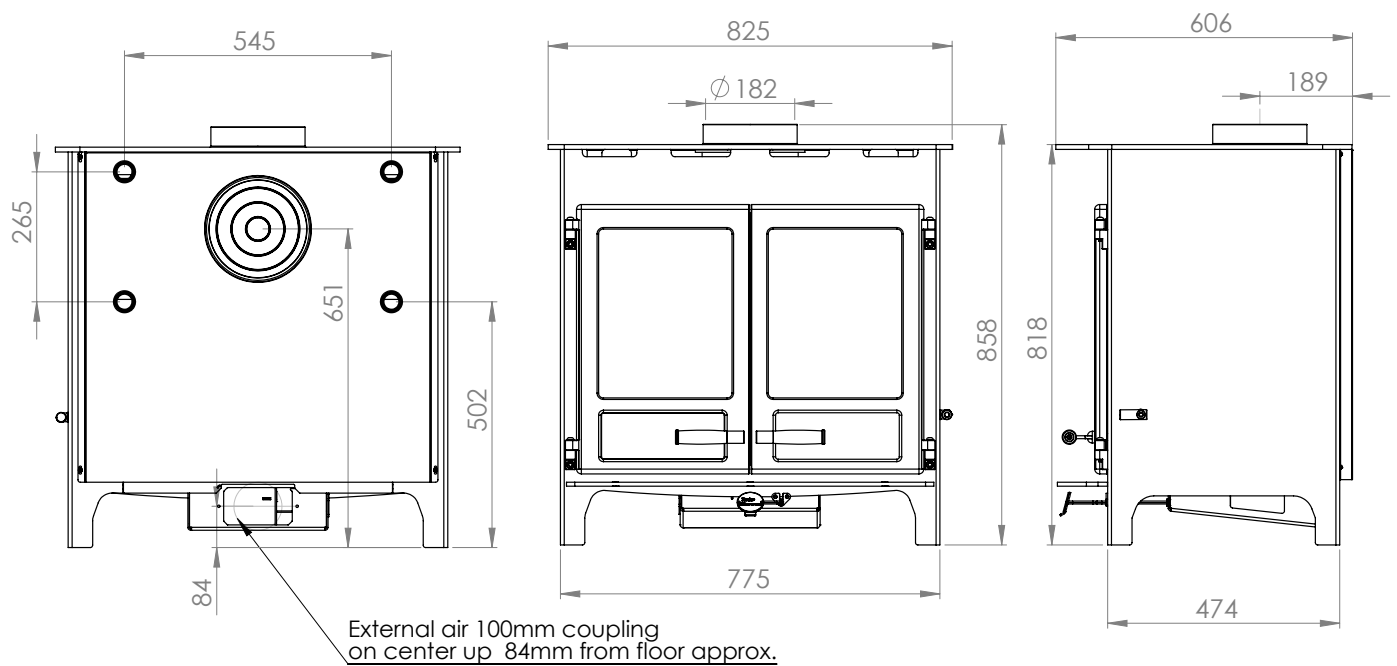

InisMor MK 2 BOILER

InisMeain MK 2 BOILER

The InisMeain Mark 2 is an upper mid sized boiler stove and it is designed for heating 12-16 radiators and domestic hot water. This stove is an excellent cost effective method of delivering sustainable, dependable heat all year round and when fuelled with wood can deliver low carbon heating.

As with the InisOirr MK 2 and InisMor MK 2, the Inis Meain MK 2 has a unique boiler and firebox arrangement that greatly improves both the stove efficiency and its ease of use. Fuel is burned in a very high temperature firebox that liberates a large percentage of the possible energy within the fuel before passing the gases from combustion through a very efficient heat exchanger that quickly heats the water within the boiler. This system is much cleaner and more efficient than all other typical boiler designs which drastically reduce combustion efficiencies by robbing the fire of heat too early in the combustion process.

Like all Inis Stoves models, all the combustion air, primary, secondary, tertiary and air wash is guided through long passageways within the stove. This air gains heat along the way

and greatly increases combustion efficiency and temperatures within the firebox.

It has a very large firebox capacity to facilitate longer burn times and can take wood logs of over 580mm in length. The multi-fuel grate is composed of individual riddler bars that can be used in two different positions to facilitate proper combustion of wood, peat and solid fuels.

The InisMeain MK 2 has a nominal boiler output of over 12.5kw and if needed easily delivers up to 17.5kw to the boiler by increasing the burn rate. The InisMeain MK 2 will easily heat 16 standard radiators along with your domestic hot water and can also be used to heat under-floor heating.

The stove is external air ready with the use of a bolt on manifold and our cool touch handles, made of Walnut, allow for safe and easy use.

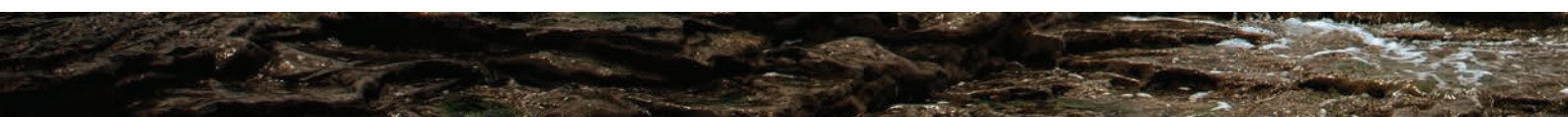

FEATURES

- Output: To water 12.5 Kw nominal, 17Kw max
- Output: To room 7.5 Kw nominal, 9 Kw max
- Comfortably heats 16 standard radiators along with Domestic hot water.
- Heavy duty cast iron baffle plates provide excellent elevated firebox temperatures.
- “Easy start” damper for quick lighting of the fire.
- Multi-fuel grate designed to burn wood, peat and smokeless coal as they should burn.
- Extra strong grate for long life under the harshest of operating conditions.
- Primary, secondary and tertiary air perfectly managed through one control.
- Exceptionally effective pre-heated air wash system provides crystal clear viewing glass.
- Unique convection air system within the stove to aid efficiency.
- Manufactured to stringent ISO 9001-2000 standards.
- 5 Year warranty.
- External air ready.
- Overnight burning capable.
- Choice of 6 colours.

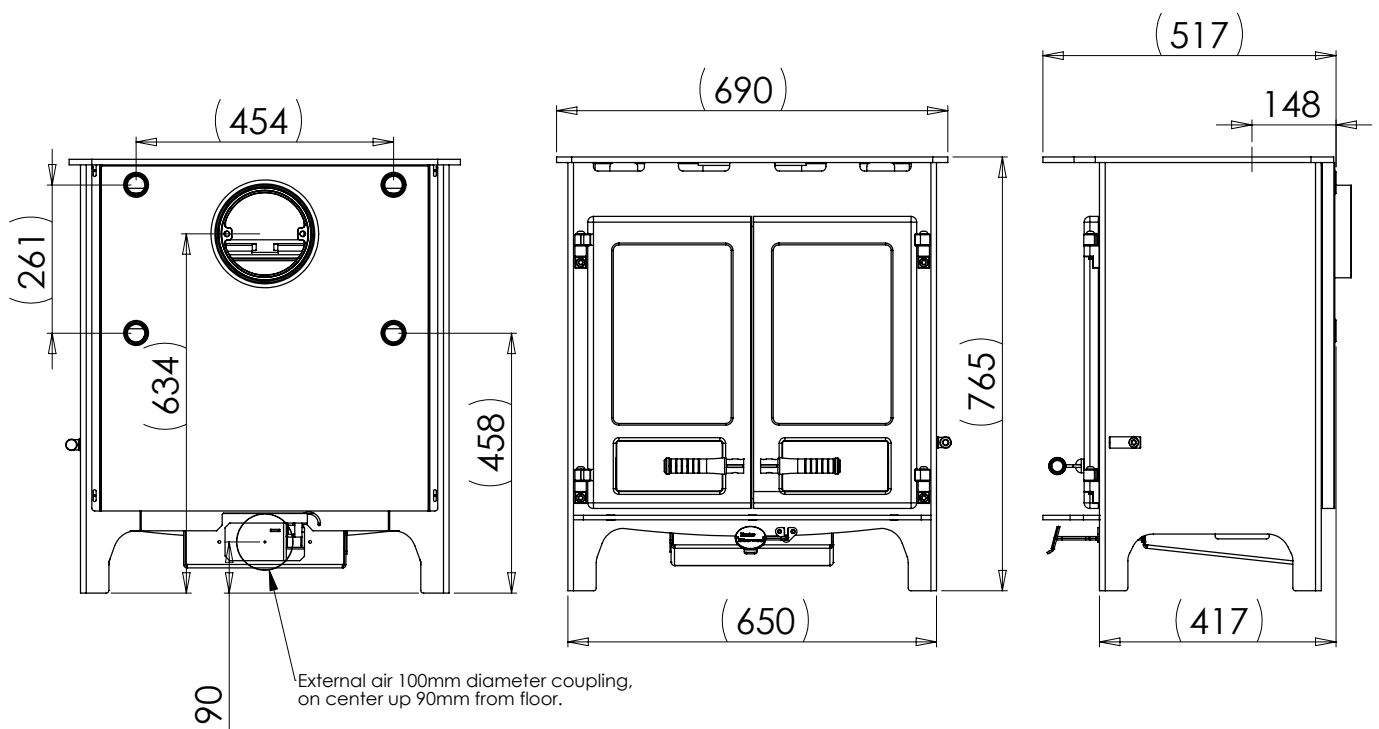

InisMeain MK 2 BOILER



InisOirr MK 2 BOILER

The InisOirr Mark 2 is the smallest of our boiler stove models and it is designed to heat 6 to 9 radiators and domestic hot water or as a supplement in a larger home along with other heat sources. The InisOirr MK 2 is an excellent cost effective method of delivering sustainable, dependable heat all year round and if fuelled with wood can be a low carbon heating system.

As with the InisMeain MK 2 and InisMor MK 2, the InisOirr MK 2 has a unique boiler and firebox arrangement that greatly improves both the stove efficiency and ease of use. Fuel is burned in a very high temperature firebox that liberates a large percentage of the possible energy within the fuel before passing the gases from combustion through a very efficient heat exchanger that quickly heats the water within the boiler.

This system is much cleaner and more efficient than all other typical boiler designs which drastically reduce combustion efficiencies by robbing the fire of heat too early in the combustion process.

Like all Inis Stoves models, all the combustion air, primary, secondary, tertiary and air wash is guided through long passageways within the stove. This air gains heat along the way and greatly increases combustion efficiency and temperatures within the firebox.

It has a very large firebox capacity to facilitate longer burn times and can take wood logs of over 500mm in length. The multi-fuel grate is composed of individual riddler bars that can be used in two different positions to facilitate proper combustion of wood, peat and solid fuels.

The InisOirr MK 2 has a nominal boiler output of over 8kw and if needed easily delivers up to 10kw to the boiler by increasing the burn rate. The InisOirr MK 2 will easily heat 9 standard radiators along with your domestic hot water and can also be used to heat under-floor heating.

The stove is external air ready with the use of a bolt on manifold and our cool touch handles, made of Walnut, allow for safe and easy use.



FEATURES

- Output: To water 8.5 Kw nominal, 10.5 Kw max
- Output: To room 5.5 Kw nominal, 7.5 Kw max
- Comfortably heats 9 standard radiators along with Domestic hot water
- Heavy duty cast iron baffle plates provide excellent elevated firebox temperatures
- “Easy start” damper for quick lighting of the fire.
- Multi-fuel grate designed to burn wood, peat and smokeless coal as they should burn
- Extra strong grate for long life under the harshest of operating conditions.
- Primary, secondary and tertiary air perfectly managed through one control.
- Exceptionally effective pre-heated air wash system provides crystal clear viewing glass
- Unique convection air system to aid efficiency
- Manufactured to stringent ISO 9001-2000 standards
- 5 Year warranty
- External air ready
- Overnight burning capable
- Choice of 6 colours

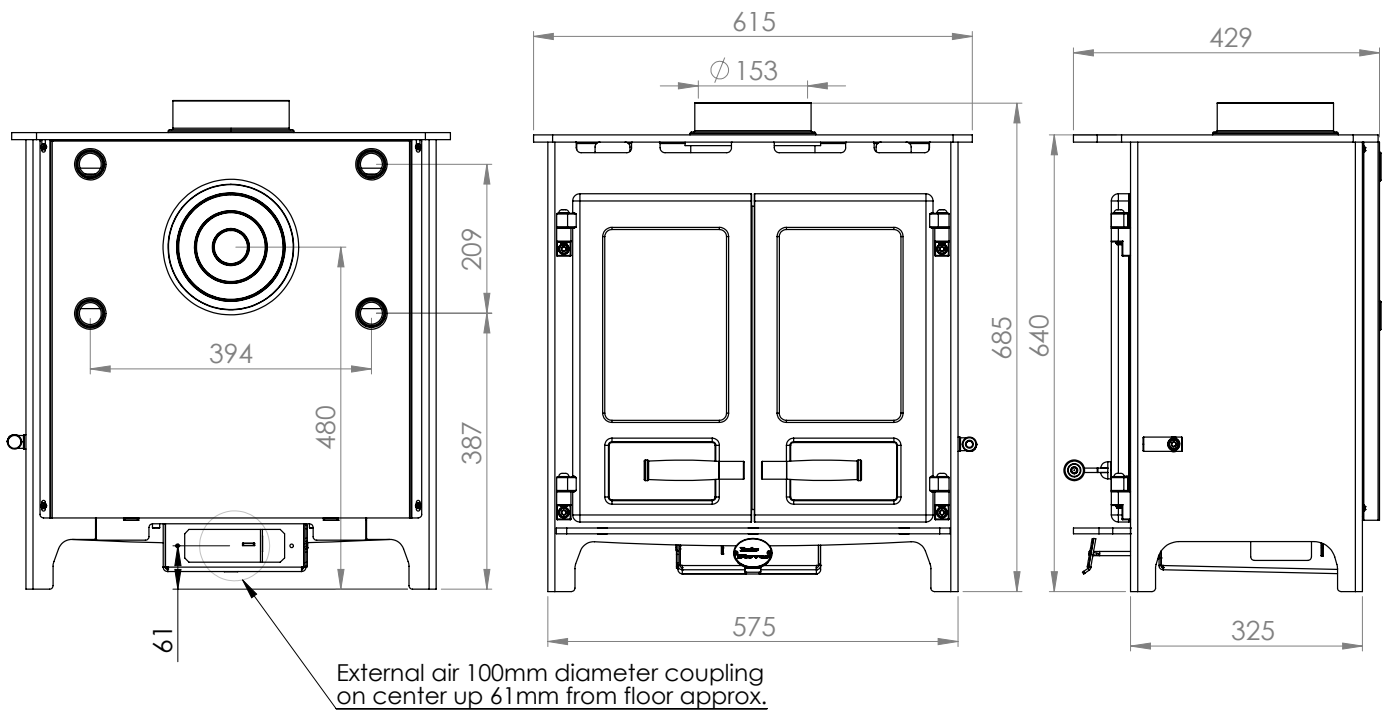

InisOirr MK 2 BOILER



Room Heating Stoves

Mainly as a result of development research undertaken with the new boiler stoves range it became apparent that our room heating stoves could be improved considerably by using some of the technical details applied to our boiler stoves.

The bottom halves of our new boiler stoves and our new room heating stoves are indistinguishable all the way up to the cast iron baffle plates. Above the baffle plates is where the magic happens. Instead of the back of the baffle plate simply heating the flue gas going up the chimney, as with almost all stoves currently on the market, our baffle plates impart this heat into two large airway ducts which carry room air up the back of the stove, along the back of the baffle plates and out the top front of the stove.

Supplementary to this detail, the flue gases are carried around these two air ducts adding greatly to the heat transfer to the room. The result of our development work is a stove that boasts a heat output that defies its physical size. Consequently our room heating stoves are highly efficient, easy to use and clean, quick to deliver heat and aesthetically pleasing with large viewing glass that stays perfectly clean.





InisMeain MK 2 ROOMHEATER

The InisMeain MK 2 room heating stove is the largest of our room heating stoves and it comfortably delivers 12kw nominal output to heat a room from 140 to 250 cubic meters in volume depending on such factors as the insulation levels of the building, the number of external walls, the amount of glazing in the room and the height of the room.

The InisMeain MK 2 is an excellent cost effective method of delivering sustainable, dependable heat all year round and if fuelled with wood can be a low carbon heating system.

As with the InisOirr MK 2 room heater, the InisMeain MK 2 has a unique large capacity convection system above the throat plates that greatly improves both the stove efficiency and heating power of the stove. This is achieved by setting up a continuous throughput of room air from beneath the stove which is channelled upwards through the hottest areas of the stove and back out into the room.

Like all Inis Stoves models, all the combustion air, primary, secondary, tertiary and air wash is guided through long passageways within the stove. This air gains heat along the way and greatly increases combustion efficiency and temperatures within the firebox.

The InisMeain MK 2 has very large firebox capacity to facilitate longer burn times and can take wood logs of over 580mm in length. The multi-fuel grate is composed of individual riddler bars that can be used in two different positions to facilitate proper combustion of wood, peat and solid fuels.

The stove is external air ready with the use of a bolt on manifold and our cool touch handles, made of Walnut, allow for safe and easy use.

All you need to do is sit back and enjoy the large view of the dancing flames from your InisMeain MK 2 stove.



FEATURES

- Up to 12kw output to room.
- Will heat a room from 140 to 250 cubic meters in volume.
- Heavy duty cast iron baffle plates provide excellent elevated firebox temperatures.
- “Easy start” damper for quick lighting of the fire.
- Multi-fuel grate designed to burn wood, peat and smokeless coal as they should burn.
- Extra strong grate for long life under the harshest of operating conditions.
- Primary, secondary and tertiary air perfectly managed through one control.
- Exceptionally effective pre-heated air wash system provides crystal clear viewing glass.
- Unique convection air system within the stove to aid efficiency.
- Manufactured to stringent ISO 9001-2000 standards.
- 5 Year warranty.
- External air ready.
- Overnight burning capable.
- Choice of 6 colours.

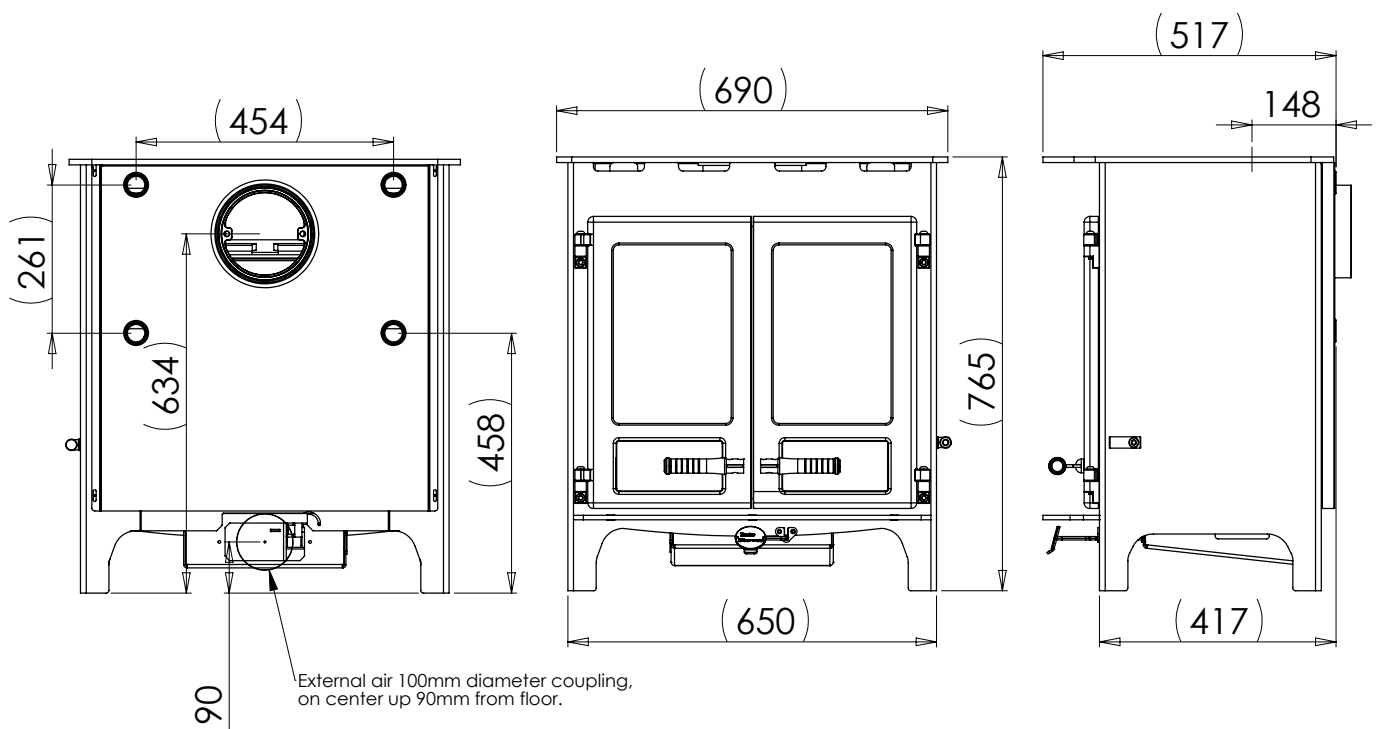

InisMeain MK 2 ROOMHEATER



InisOirr MK 2 ROOMHEATER

The Inis Oirr MK 2 room heating stove is a mid-sized stove comfortably delivering 9kw nominal output to heat a room from 100 to 180 cubic meters in volume depending on such factors as, the insulation levels of the building, the number of external walls, the amount of glazing in the room and the height of the room.

The Inis Oirr MK 2 is an excellent cost effective method of delivering sustainable, dependable heat all year round and if fuelled with wood can be a low carbon heating system. As with the Inis Meain MK 2 room heater, the Inis Oirr MK 2 has a unique large capacity convection system above the throat plates that greatly improves both the stove efficiency and heating power of the stove. This is achieved by setting up a continuous throughput of room air from beneath the stove that is channelled upwards through the hottest areas of the stove and back out into the room. As with all Inis Stoves models, all the combustion air, primary,

secondary, tertiary and air wash is guided through long passageways within the stove. This air gains heat along the way and greatly increases combustion efficiency and temperatures within the firebox.

It has a very large firebox capacity to facilitate longer burn times and can take wood logs of over 500mm in length. The multi-fuel grate is composed of individual riddler bars that can be used in two different positions to facilitate proper combustion of wood, peat and solid fuels.

The stove is external air ready with the use of a bolt on manifold and our cool touch handles, made of Walnut, allow for safe and easy use. All you need to do is sit back and enjoy the large view of the dancing flames from your Inis Oirr MK 2 stove.



FEATURES

- Up to 9.0kw output to room.
- Will heat a room from 100 to 180 cubic meters in volume.
- “Easy start” damper for quick lighting of the fire.
- Heavy duty cast iron baffle plates provide excellent elevated firebox temperatures.
- Multi-fuel grate designed to burn wood, peat and Smokeless coal as they should burn.
- Extra strong grate for long life under the harshest of operating conditions.
- Primary, secondary and tertiary air perfectly managed through one control.
- Exceptionally effective pre-heated air wash system provides crystal clear viewing glass.
- Unique convection air system within the stove to aid efficiency.
- Manufactured to stringent ISO 9001-2000 standards
- 5 Year warranty.
- External air ready.
- Overnight burning capable.
- Choice of 6 colours.

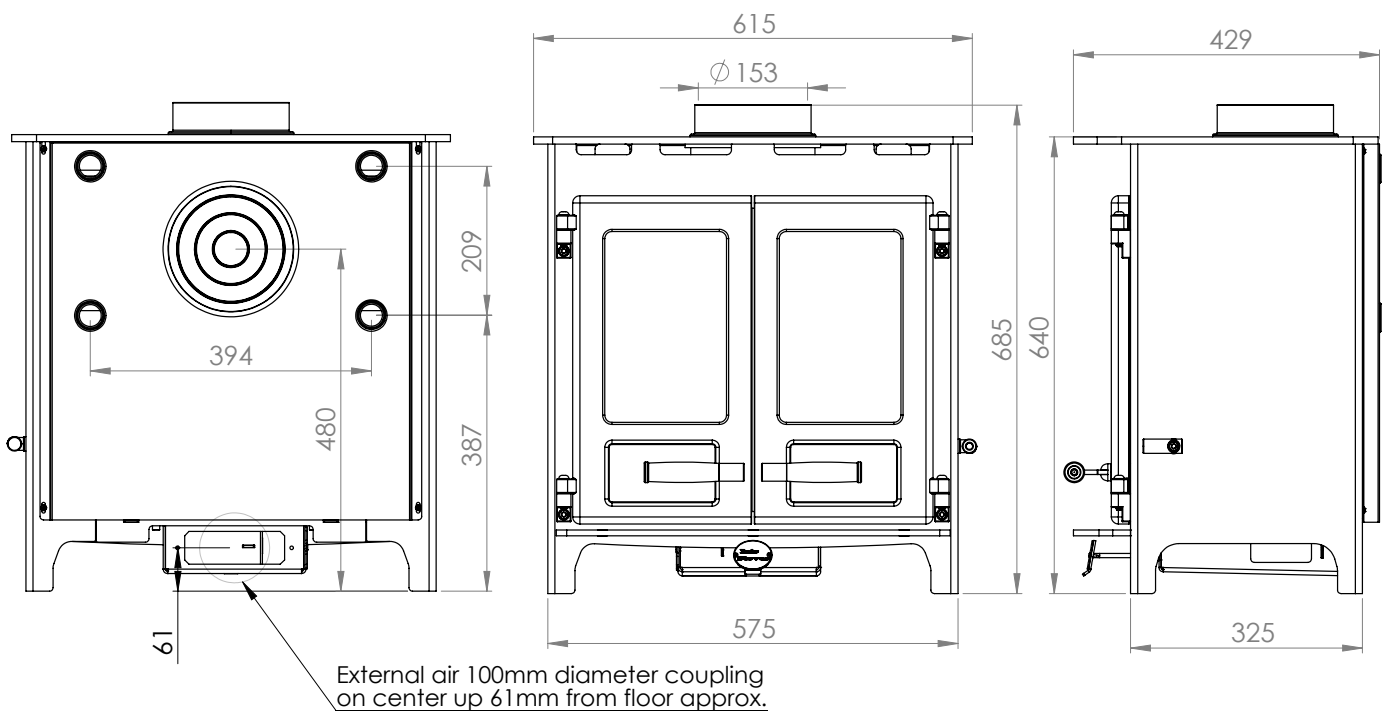

InisOirr MK 2 ROOMHEATER

InisAirc ROOMHEATER

The Inis Airc is ideal for fireplace settings and, whilst the smallest of the Inis models, it boasts an exceptionally powerful heating capacity delivering up to 6kw. The simple, elegant look of this classic stove will compliment any room.

Inis Airc's advanced convection and clean burn technology provide a considerable saving on fuel over standard stoves resulting in more heat from less fuel. This is better for your pocket and the environment. Our clean-burn air-wash also keeps the glass beautifully clear, giving you an uninterrupted view of the fire. The Inis Airc is available in a variety of 6 colours.

Convection Air System "More Heat, Less Fuel"

All Inis stoves include a convection system whereby cool air from within the room is drawn into the convection chamber. This air is then heated as it rises within the stove flows out into the room. The hot air rising draws in more cool air setting up a continuous flow maintaining added heating efficiency.



FEATURES

- Up to 6kw output.
- Convection and Cleanburn system gives you increased efficiency and reduced emissions.
- Airwash system ensures clean glass giving you uninterrupted view of the fire.
- Single door stove, made from a combination of 5mm, 8mm and 10mm boiler plate steel, cast iron, ceramic glass and firebrick lining.
- Will heat a room up to 400 square feet.
- Outside air kit available.
- 5 inch Flue outlet, top and rear.
- Heavy duty Multi-fuel grate burns wood, smokeless coal, peat & eco fuels.
- A wooden handle for safe and easy reloading.
- Full external riddling mechanism makes stoking the fire much safer.
- Fully controllable damper for safer and easier operation.
- Overnight burning capable.
- Removable ash pan.
- Variety of 6 colours available including various colour handles.
- Fully manufactured in Ireland to ISO9001-2000 standards.
- Full 5 year guarantee.

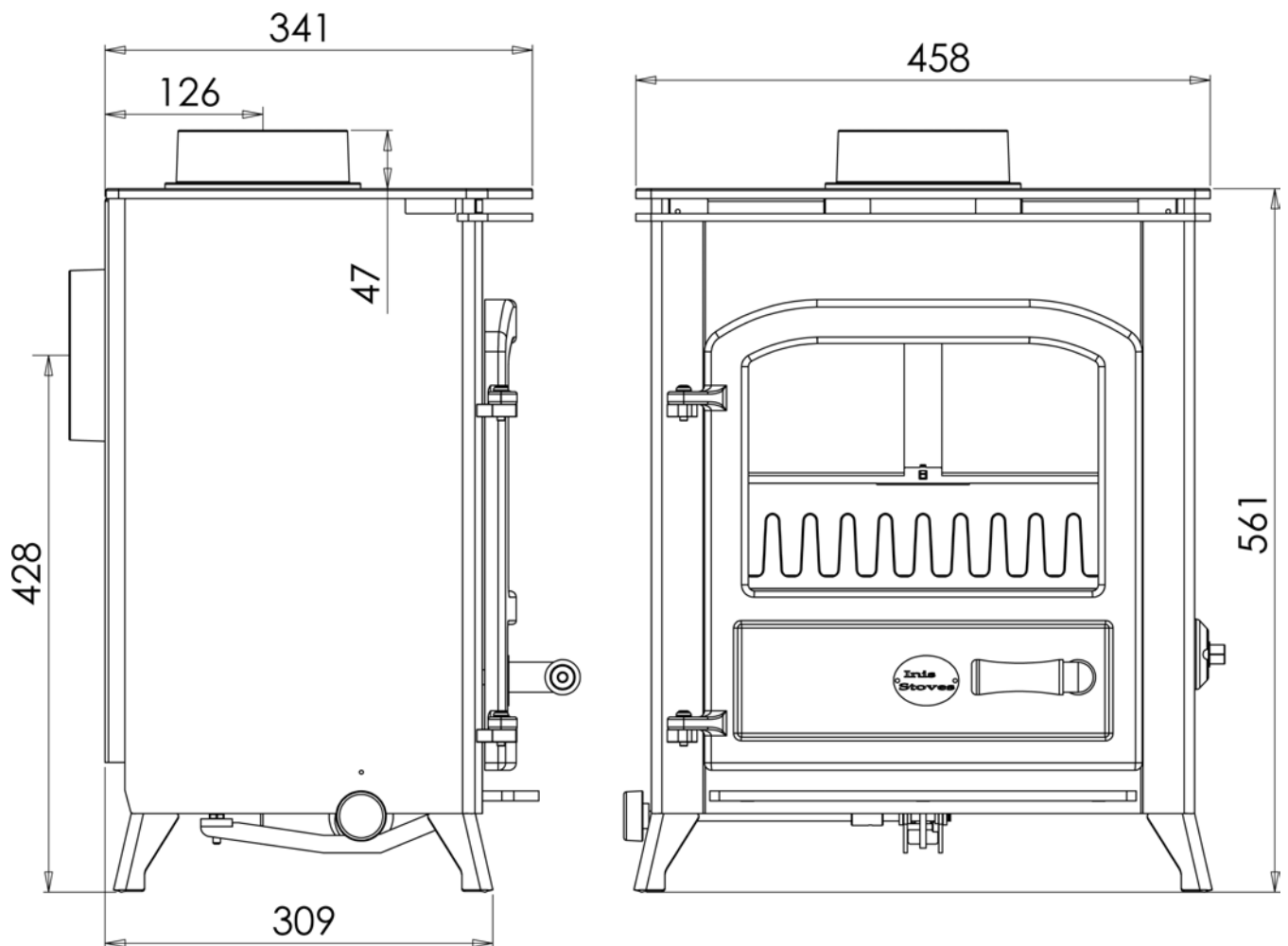

InisAirc ROOMHEATER



InisAirc Ard ROOMHEATER

The InisAirc Ard has an impressive 6Kw output. This stove has a sizable wood store and a large base plate offering a more contemporary slant on the standard InisAirc. This stove is ideal for large open plan areas and conservatories.

Its advanced convection and clean burn technology provides a considerable saving on fuel over standard stoves resulting in more heat from less fuel. This is better for your pocket and the environment. Our clean-burn air-wash also keeps the glass beautifully clear, giving you an uninterrupted view of the fire. The InisAirc Ard is available in a variety of 6 colours.

Convection Air System "More Heat Less Fuel"

All Inis stoves include a convection system whereby cool air from within the room is drawn into the convection chamber. This air is then heated as it rises within the stove and then flows out into the room. The hot air rising draws in more cool air setting up a continuous flow maintaining added heating efficiency.



FEATURES

- Up to 6kw output.
- Convection and Cleanburn system gives you increased efficiency and reduced emissions.
- Airwash system ensures clean glass giving you uninterrupted view of the fire.
- Single door stove, made from a combination of 5mm, 8mm and 10mm boiler plate steel, cast iron, ceramic glass and firebrick lining.
- Will heat a room up to 400 square feet.
- Outside air kit available.
- 5 inch Flue outlet, top and rear.
- Heavy duty Multi-fuel grate burns wood, smokeless coal, peat & eco fuels.
- A wooden handle for safe and easy reloading.
- Full external riddling mechanism makes stoking the fire much safer.
- Fully controllable damper for safer and easier operation.
- Overnight burning capable.
- Removable ash pan.
- Variety of 6 colours available including various colour handles.
- Fully manufactured in Ireland to ISO9001-2000 standards.
- Full 5 year guarantee.

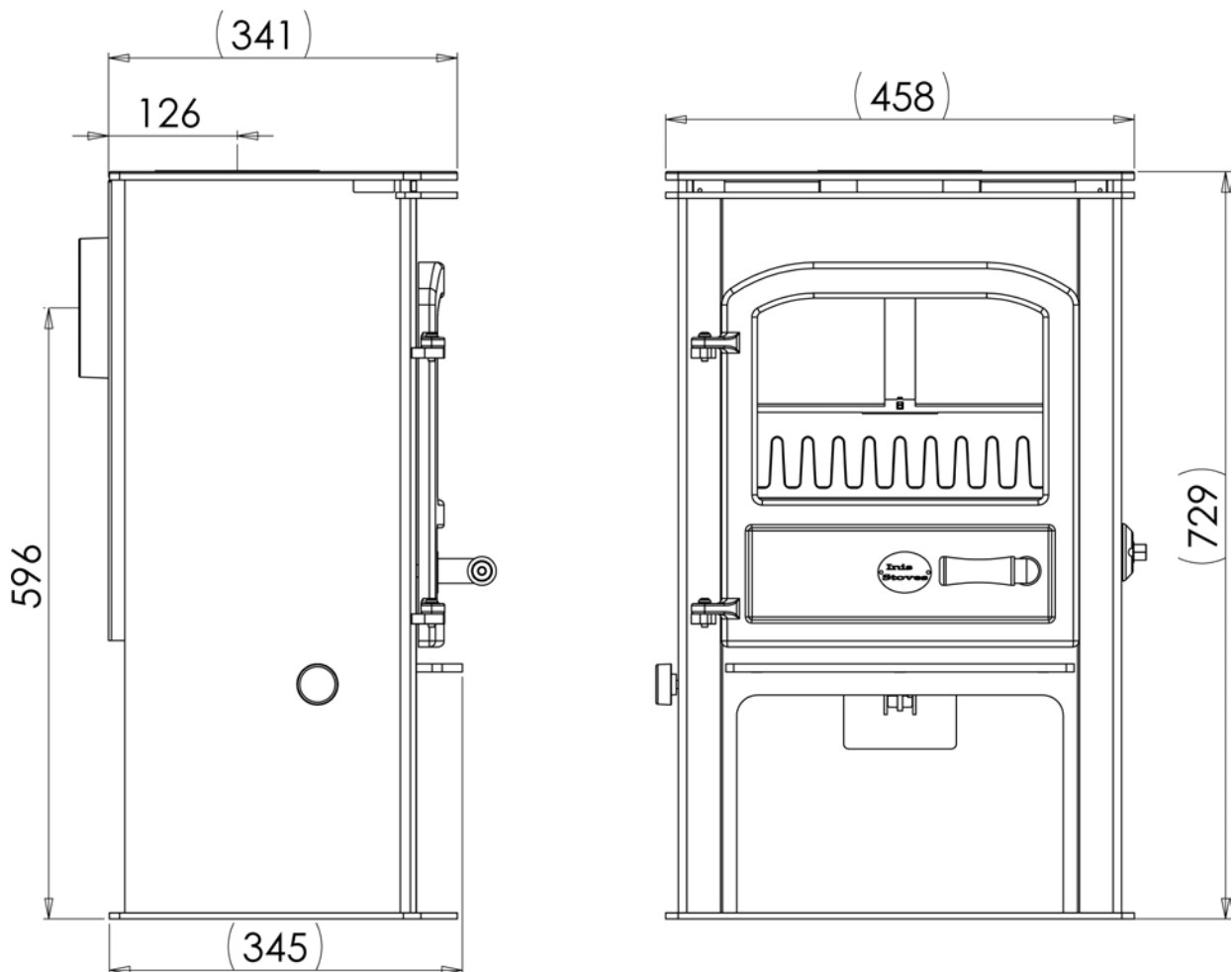

InisAirc Ard ROOMHEATER



Insert Stoves

Insert stoves have become very popular in the past number of years for obvious reasons. There are many rooms where a full free-standing stove is not visually suitable for the style of the room or is not practical due to the room layout or size. In these cases an insert stove is often the answer.

Insert stoves are both an economical and environmentally sound alternative to an open fire as well as being substantially more heat efficient. A typical open fireplace is very inefficient at between 15% - 30% and can lead to serious draughts within the room and building.

When replaced with an insert stove the added heating efficiency and prevention of draughts even when the stove is not alight will result in a much more comfortable room.





InisBofin INSERT STOVES

The InisBofin Insert Stove transforms a standard fireplace into an efficient and environmentally sound source of heat.

Gone are the cold draughts, smoking chimneys and high heating costs, replaced with a highly efficient, sleek, clean modern convector Insert Stove.

Best of all, due to the large viewing glass and latest control and cleanburn technology you retain the beautiful look of an open fire.

Convection Air System "More Heat Less Fuel"

All Inis stoves include a convection system whereby cool air from within the room is drawn into the convection chamber. This air is then heated as it rises within the stove and then flows out into the room. The hot air rising draws in more cool air setting up a continuous flow maintaining added heating efficiency.



FEATURES

- Up to 5kw nominal and 7kw maximum output.
- Fits into a standard 16" or 18" fireplace.
- Up to 5 times more efficient than an open fire.
- Primary, secondary and tertiary air provides cleaner and more efficient combustion.
- Sealed high temperature air-wash system ensures clean glass giving you uninterrupted view of the fire.
- Unique damper for greater control and ease of use.
- Cool touch and removable handle for safe and easy reloading.
- Full external riddling mechanism makes stoking the fire much safer.
- Heavy duty multifuel grate burns wood, smokeless coal and peat.
- Overnight burning capable.
- Removable ash pan.
- Variety of 6 colours available.
- Full 5 year guarantee.

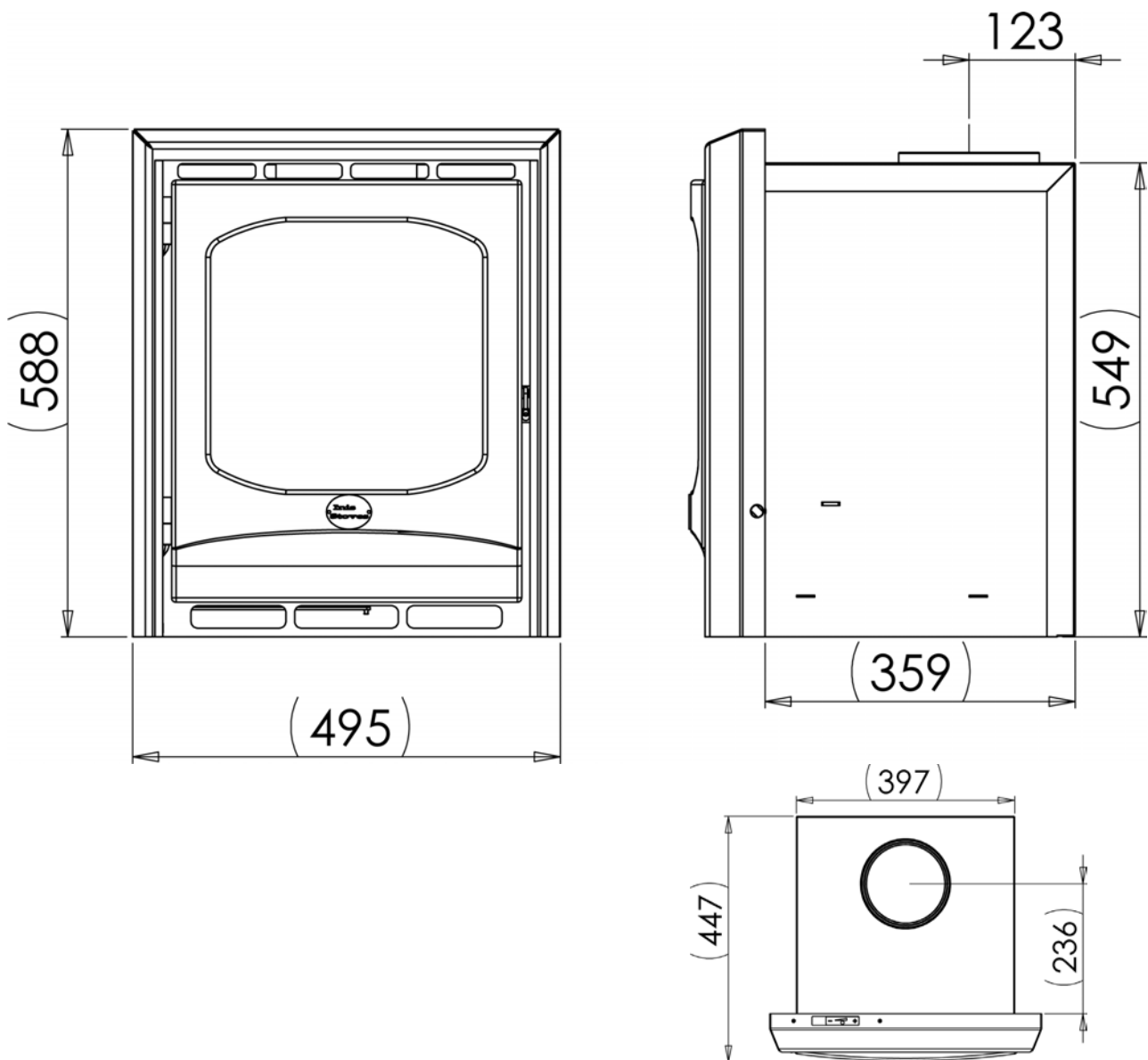

InisBofin INSERT STOVES



COLOUR OPTIONS

At Inis Stoves we have strived to create a choice of colours to suit all tastes. Whether you like a sensual red, a regal bronze or light and airy almond we hope to have one for you. Bespoke colours can be ordered but please note there is an extra cost (dependent on the particular colour) and a longer waiting time.



Black



Almond



Charcoal



Red



Brown



Bronze

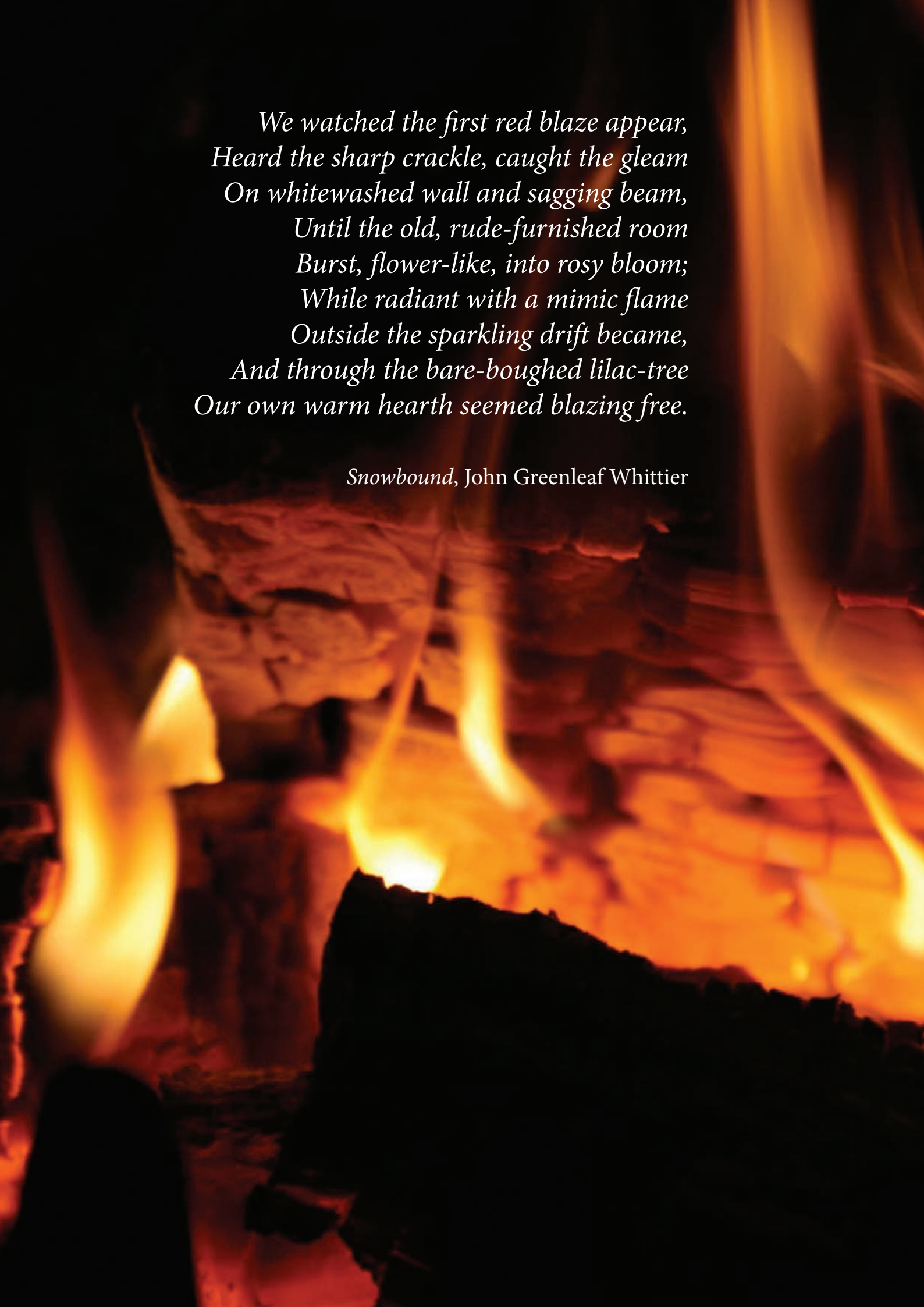

*We watched the first red blaze appear,
Heard the sharp crackle, caught the gleam
On whitewashed wall and sagging beam,
Until the old, rude-furnished room
Burst, flower-like, into rosy bloom;
While radiant with a mimic flame
Outside the sparkling drift became,
And through the bare-boughed lilac-tree
Our own warm hearth seemed blazing free.*

Snowbound, John Greenleaf Whittier

